

# VG9000 Series Flanged Valves

## DN 15 – DN 100 • Cast Iron • PN 6 (K) & PN 10 (L)



### Introduction

*This improved VG9000 Series cast iron flanged valves are designed primarily to regulate the flow of water and low pressure steam in response to the demand of a controller, in heating, ventilating, and air conditioning systems. These valves are available in two-way Push-Down-To-Open and three way mixing configurations.*

*Five models of electric actuator are available as standard for this valve: The VA-7150\* and VA-7700 for DN 15...DN 50, VA-7200\*, and VA7810 for DN 15...DN 65 and the RA-3000 for DN 65...DN 100 valves. Each model can be ordered with either 3-point or 0...10 V DC proportional control. The VA-7700 and VA7810 proportional control models have a self adjusting function for quick, easy and precise commissioning and servicing.*



**VG9000 Series Valves**

\* To be discontinued Oct. 2005

### Features and Benefits

<input type="checkbox"/> <b>PN 6 and PN 10 rated series from DN 15 to DN 100 in two-way PDTTO and three-way mixing configurations</b>	Covers many common low pressure HVAC applications
<input type="checkbox"/> <b>Full DIN / IEC flow capacity for all valves DN 15... DN 100</b>	Cost efficient, offers maximum flow capacity per DN size
<input type="checkbox"/> <b>Uses Johnson Controls dual u-cup ring packing</b>	Provides Industry-leading reliability and long life
<input type="checkbox"/> <b>Brass Plug with soft seal for tight shut-off on both control and by-pass ports</b>	Provides maximum energy efficiency
<input type="checkbox"/> <b>Electric actuators available either factory mounted, or separately for in-situ installation</b>	Provides the optimal selection either for direct installations or for distribution centres
<input type="checkbox"/> <b>Face to Face dimensions in accordance with DIN / IEC standards</b>	Easier application in existing installations
<input type="checkbox"/> <b>Clamp coupler system for all sizes</b>	The same actuators for all JCI flanged valves

## Application Overview

Valve bodies are made of cast iron and are available in sizes from DN 15 to DN 100. Flange fittings comply with EN1092-2 and ISO 7005-2 standards. The valve features a brass plug with soft seal and a stainless steel stem guided by dual u-cup ring packing.

The VG9000 valve is available in two-way configurations for Push-Down-To-Open operation and in three-way mixing configurations.

Two-way valves have equal percentage relationship between valve travel and flow at a constant pressure drop. Three-way valves have a combination of equal percentage and linear characteristic. An arrow is embossed on one side of the valve body indicating the direction of flow for correct installation.

Four models of electric actuator are available as standard and can be ordered either as factory fitted actuator / valve combinations or separately for in-situ installation.

Refer to this and the following pages for ordering data and additional details.

## Ordering codes for Valve Bodies VG9000

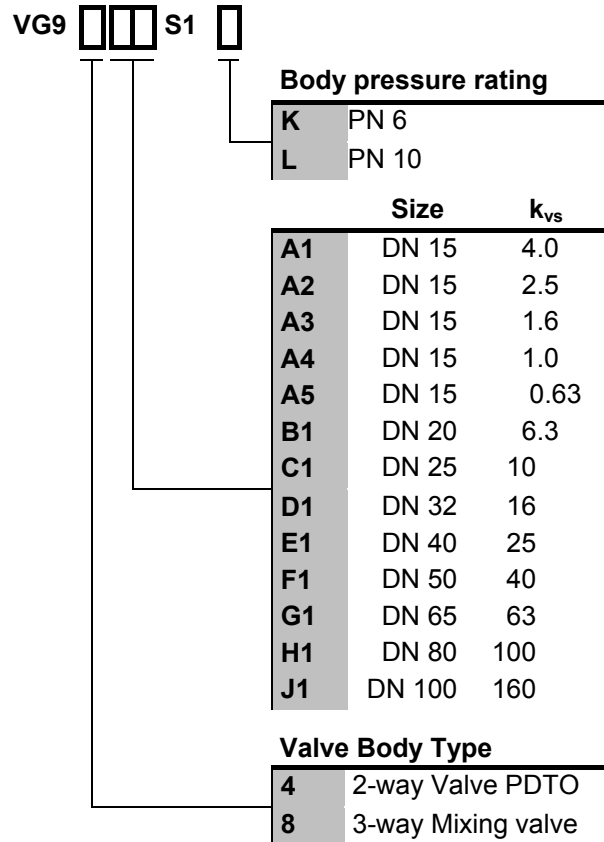

### For Example:

For a two-way valve, DN 65,  $k_{vs}$  63, PN 10, the ordering code is:

**VG94G1S1L**

# Valve selection

The valve size for water applications can be defined using the diagram below, where the intersection of the pressure drop over the valve and the flow has to stay within the white area.

***k<sub>v</sub> selection diagram for DN 15...100 valves:***

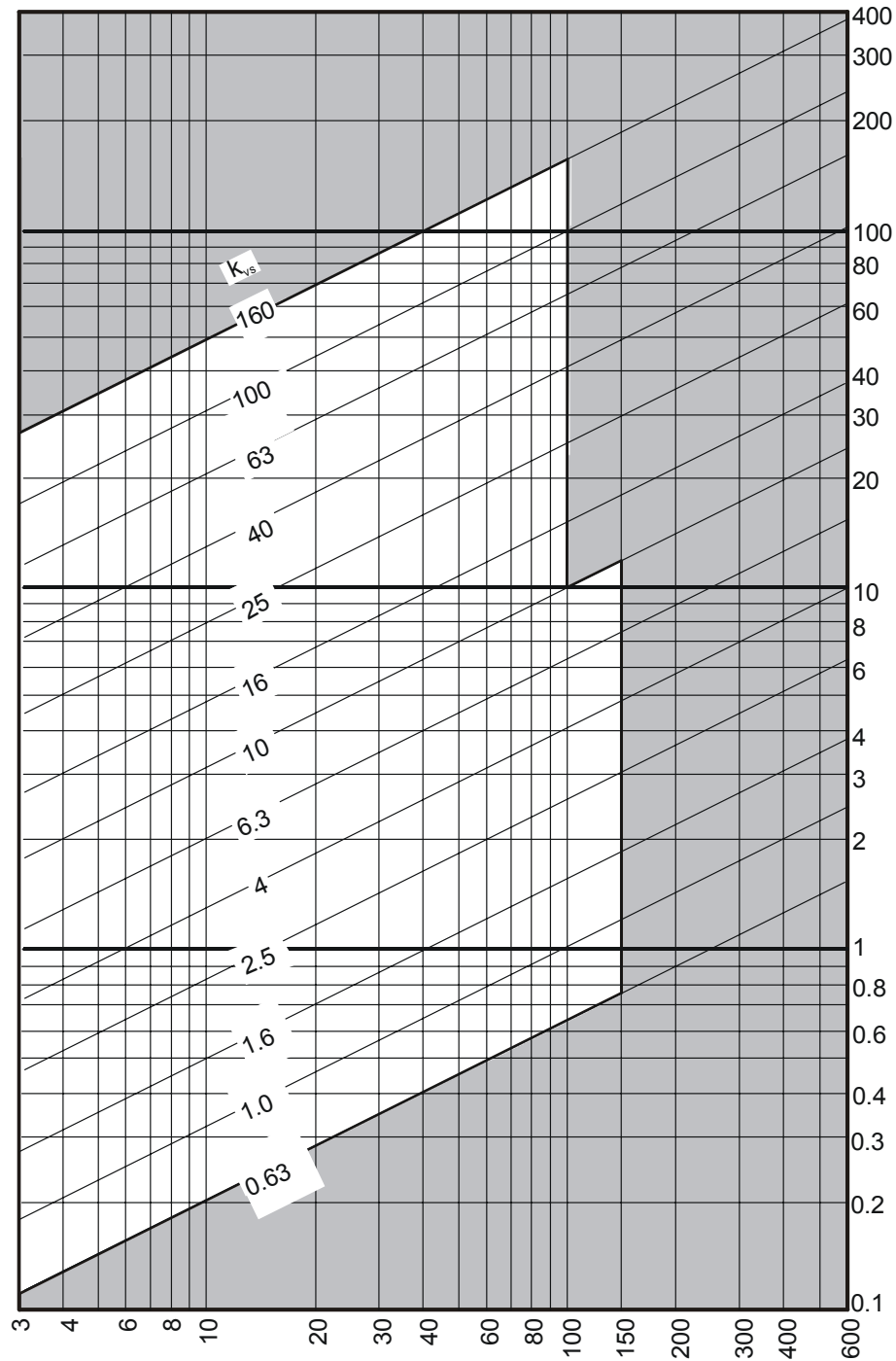

Pressure drop  $\Delta p$ , in kPa (100 kPa = 1 bar)

## Valve - actuator combinations

This improved VG9000 series cast iron flanged valves can be combined with the following series pneumatic and electric actuators:

VA-7150\* electric actuator (DN 15...DN 50)

VA-7700 self-adjusting actuator (DN 15...DN 50)

VA-7200\* electric actuator (DN 15...DN 65)





VA-7810 self-adjusting actuator (DN 15...DN 65)

RA-3000 electric actuator (DN 65...DN 100)

\* To be discontinued Oct. 2005

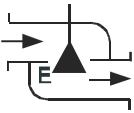
### Actuator Selection

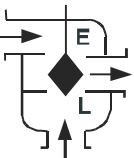
Flow through the valve is dependent on the position of the plug, as indicated in the tables below. The function of the actuator / valve combination is dependent upon the action of the actuator and the type of valve used.

Valve Type	Electric Actuator
 <b>VG94xxS1x</b> 2-way PDTO	 Actuator stem extends
	 Actuator stem retracts
 <b>VG98xxS1x</b> 3-way mixing	 Actuator stem extends
	 Actuator stem retracts
E = Equal % control characteristic    ▲ = Flow L = Linear control characteristic      △ = No flow	

### VA-7150 Electric Actuators

The VA-7150 series synchronous motor-driven actuator is available for 3-point (floating) control, with or without feedback and for proportional DC 0...10 V.

It provides 500 N nominal stem force and can be used with DN 15...DN 50 mixing and DN 15...DN 50 two-way PDTO valve configurations in accordance with the max. close-off pressure ratings specified.

#### Ordering codes for VA-7150 Electric Actuators

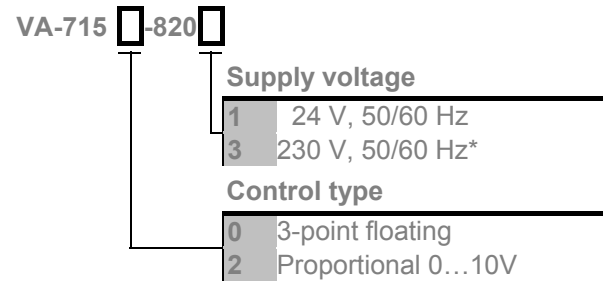

\* 3-point floating models only

**Note:** 3-point floating models with 2kΩ feedback or (1) auxiliary switch are available on request. Manual override is not available.

### VA-7700 Electronic Actuators

The VA-7700 series synchronous motor-driven actuator is available with 3-point (floating) control and optional manual override, or proportional DC 0...10 V models with a **self-adjustment** feature for easy, quick, precise commissioning and servicing. It provides 500 N nominal thrust and can be used with DN 15...DN 50 two-way and mixing valve configurations in accordance with the max. close-off pressure ratings specified

#### Device codes for VA-7700 Electric Actuators

Device code	Power supply	Manual override
<b>Incremental models (3-point)</b>		
<b>VA-7700-8201</b>	AC 24 V	None
<b>VA-7700-8203</b>	AC 230 V	None
<b>VA-7740-8201</b>	AC 24 V	Mechanical
<b>VA-7740-8203</b>	AC 230 V	Mechanical
<b>Proportional models (DC 0...10 V / 0 (4)...20mA)</b>		
<b>VA-7706-8201</b>	AC 24 V	Electrical
<b>VA-7746-8201</b>	AC 24 V	Electrical and Mechanical

**VA-7200 Electric Actuators**

(To be discontinued Oct. 2005)

The VA-7200 series synchronous motor-driven actuator is available for 3-point (floating) control, with or without feedback and for proportional DC 0...10 V control with or without feedback.

It provides 1000 N nominal stem force and can be used with DN 15...DN 65 valves in accordance with the max. close-off pressure ratings specified.

**Ordering codes for VA-7200 Electric Actuators**

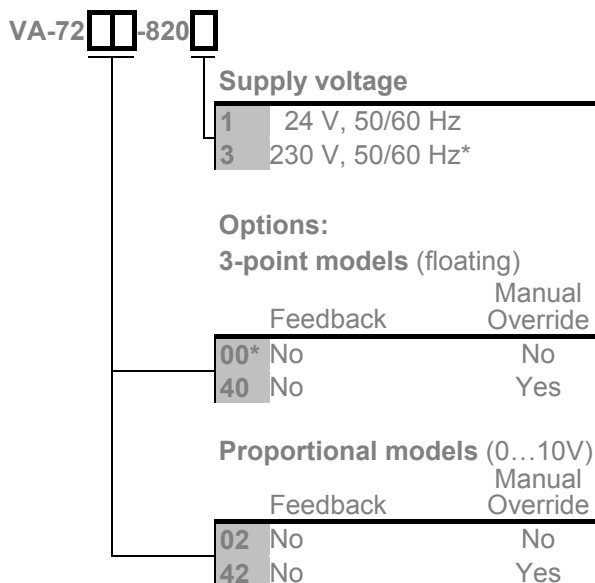

(\*) Only models VA-7200-1003 and VA-7240-1003 are available with AC 230 V power supply.

**Note:** Models with manual override and AC 24 V power supply are equipped with a power cut-off switch.

For complete ordering data see the VA-7200 product bulletin.

**VA7810 Electric Actuators**

The VA7810 non-spring return actuator with 1000N thrust for valves in heating, ventilation and air conditioning applications is available for floating (3-point) control or proportional control.

All models have manual override as standard. Proportional models are **self-calibrating**. The actuator is intended for use with Johnson Controls VG9000 flanged valves.

It provides 1000 N nominal stem force and can be used with DN 15...DN 65 valves in accordance with the max. close-off pressure ratings specified.

**Ordering codes for VA7810 Electric Actuators**

Ordering code	Actuator Description
	<b>Floating Control</b>
VA7810-ADA-12	AC 230 V
VA7810-AGA-12	AC 24 V
VA7810-AGC-12	AC 24 V, 2 aux. switches
VA7810-AGH-12	AC 24 V, 2kΩ Feedback pot.
	<b>Proportional Control</b>
VA7810-GGA-12	AC 24 V DC 0(2)...10 V or 0(4)... 20 mA
VA7810-GGC-12	AC 24 V 2 Aux. switches DC 0(2)...10 V or 0(4)... 20 mA

### RA-3000 Electric Actuators

The RA-3000 series, synchronous motor-driven actuator is available for 3-point (floating) or DC 0...10 V proportional control. It features factory calibrated limit switches to provide specified close-off ratings.

This actuator is available for the improved VG9000 series in two sizes, the RA-3xxx-712x with 1600 N minimal thrust for size DN 65 and the RA-3xxx-732x with 3000 N minimal thrust for size DN 80...100 valves in accordance with the max. close-off pressure ratings specified. Factory fitted options, such as a 2k $\Omega$  feedback potentiometer, auxiliary switches and manual override are available.

**Note:** The adapter nut must be removed from the valve before the RA-3000 actuator can be fitted!

### Ordering codes for RA-Electric Actuators

RA-3       -7         

#### Force & Supply Voltage

<b>126</b>	1600 N	24 V, 50/60 Hz
<b>127</b>	1600 N	230 V, 50/60 Hz
<b>325</b>	3000 N	24 V, 60 Hz
<b>326</b>	3000 N	24 V, 50 Hz
<b>327</b>	3000 N	230 V, 50 Hz

#### Options, factory mounted

<b>00</b>	None
<b>03</b>	(2) Aux. switches and 2 k $\Omega$ feedback potentiometer
<b>41</b>	Positioner 0...10 VDC and (2) Aux. switches (only 24 VAC models)

#### Manual override

<b>0</b>	None
<b>1</b>	with Manual override

### Ordering procedure

The valves and actuators can be ordered separately or factory mounted. When factory mounted, please add “**+M**” to the order code for the actuator.

#### For example:

For a 2-way PN 10, DN 65, K<sub>vs</sub> 63, valve plus actuator with electric positioner, 0...10 V input, AC 24 V 50/60 Hz supply and manual override order:

Item 1 **VG94G1S1L** (valve body)  
Item 2 **VA7810-GGA12** (actuator)

Alternatively, to order a factory fitted combination:

Item 1 **VG94G1S1L** (valve body)  
Item 2 **VA7810-GGA12+M** (actuator)

# Close-off pressures

Maximum Close-off pressures for electric actuator / valve combinations (kPa)

		Valve body Size DN								
		15	20	25	32	40	50	65	80	100
$k_{vs}$		*	6.3	10	16	25	40	63	100	160

Actuator	Thrust (N)	PN 6 close-off pressures																
VA-7150-1000	500	600			590	490	360	280	190	130	100	60	-	-	-	-	-	
VA-7700-1000		600			-	-	-	-	-	-	-	-	-	-	-	-	-	
VA-7200-1000	1000	600			-	-	-	-	480	440	290	260	150	130	-	-		
VA7810-xxx-12	1000	600			-	-	-	-	-	-	-	-	-	-	-	-		
RA-3000-712x	1600	-	-	-	-	-	-	-	-	-	-	-	380	360	-	-		
RA-3000-732x	3000	-	-	-	-	-	-	-	-	-	-	-	-	-	510	500	320	310

		PN 10 close-off pressures																	
VA-7150-1000	500	1000	980	880	640	430	400	240	210	110	110	40	-	-	-	-	-		
VA-7700-1000		1000	980	880	640	430	400	240	210	110	110	40	-	-	-	-	-		
VA-7200-1000	1000	1000			-	-	-	900	790	510	420	310	240	160	120	-	-		
VA7810- xxx-12	1000	1000			-	-	-	900	790	510	420	310	240	160	120	-	-		
RA-3000-712x	1600	-	-	-	-	-	-	-	-	-	-	-	-	390	360	-	-		
RA-3000-732x	3000	-	-	-	-	-	-	-	-	-	-	-	-	-	-	510	490	320	310

\* 0.63 / 1 / 1.6 / 2.5 / 4

## Installation and Servicing

When mounting the VG9000 series valves, please follow the instructions below:

- It is recommended that the valves be mounted upright, in a conveniently accessible location.
- The actuator must not be covered with insulating material.
- Sufficient clearance must be allowed for actuator removal (refer to the dimension drawings).
- Install the valve so that the plug seats against the direction of flow as indicated by the arrow(s) embossed on the valve body.
- Johnson Controls must approve use of the VG9000 series valves with fluids other than specified.
- On electrically actuated valve assemblies, all wiring must be in accordance with applicable electrical code requirements.
- Input lines to the actuator must be wired correctly to open or close the valve as intended.

When servicing the VG9000 series valves, make sure that:

- The electrical power to the actuator is isolated.
- You do not touch or attempt to connect or disconnect wires when electrical power is on.

**WARNING**

**Shock Hazard**  
Disconnect the power supply before wiring connections are made to prevent personal injury.

**Equipment Damage Hazard**  
Make and check all wiring connections before applying power to the system. Short circuited or improperly connected wires may result in permanent damage to the unit.

- No pressure is applied to the piping system when servicing the valve.

### Ordering Code for Replacement Packing Kits

Ordering Code	For valves
VG7000-6001	DN 15...40
VG7000-6002	DN 50...100

## Dimensions (in mm): Electric actuators VA-7150, VA-7200 and RA-3000

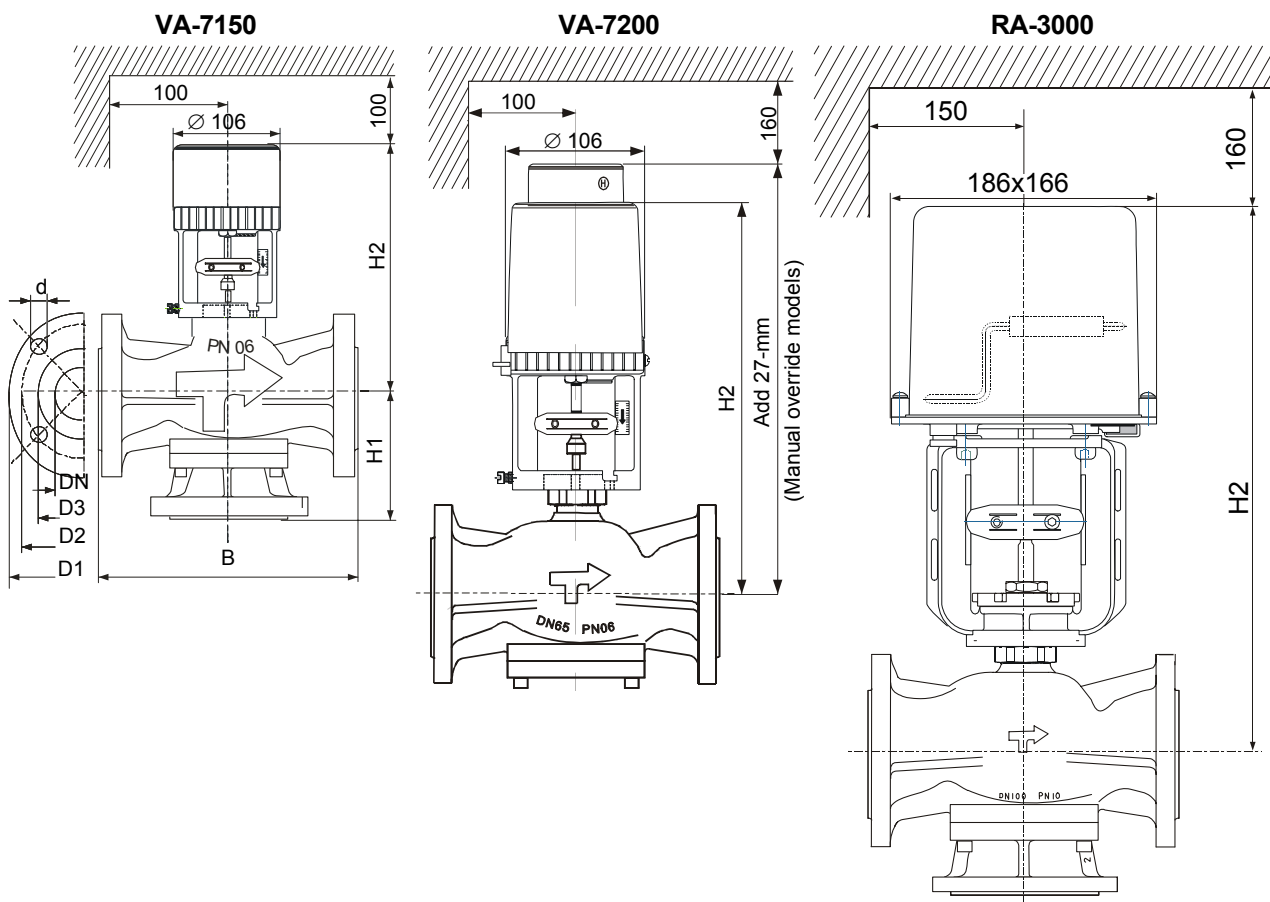

### Valve and actuator dimensions.

DN	VA-7150		VA-7200		RA-3000	
	PN 6	PN 10	PN 6	PN 10	PN 6	PN 10
15				264		
20				264		
25				288		
32				299		
40				298		
50				305		
65				333		388
80						401
100						413

DN	PN 6								PN 10							
	B	D1	D2	D3	d	H1	Holes	B	D1	D2	D3	d	H1	Holes		
15	130	80	55	38	11	65	4	130	95	65	46	14	65	4		
20	140	90	65	48	11	70	4	150	105	75	56	14	75	4		
25	150	100	75	58	11	75	4	160	115	85	65	14	80	4		
32	180	120	90	69	14	90	4	180	140	100	76	19	90	4		
40	180	130	100	78	14	90	4	200	150	110	84	19	100	4		
50	200	140	110	88	14	100	4	230	165	125	99	19	115	4		
65	240	160	130	108	14	120	4	290	185	145	118	19	145	4		
80	260	190	150	124	19	130	4	310	200	160	132	19	155	8		
100	300	210	170	144	19	150	4	350	220	180	156	19	175	8		

# Dimensions (in mm): Self-adjusting electric actuators VA-7700 and VA7810

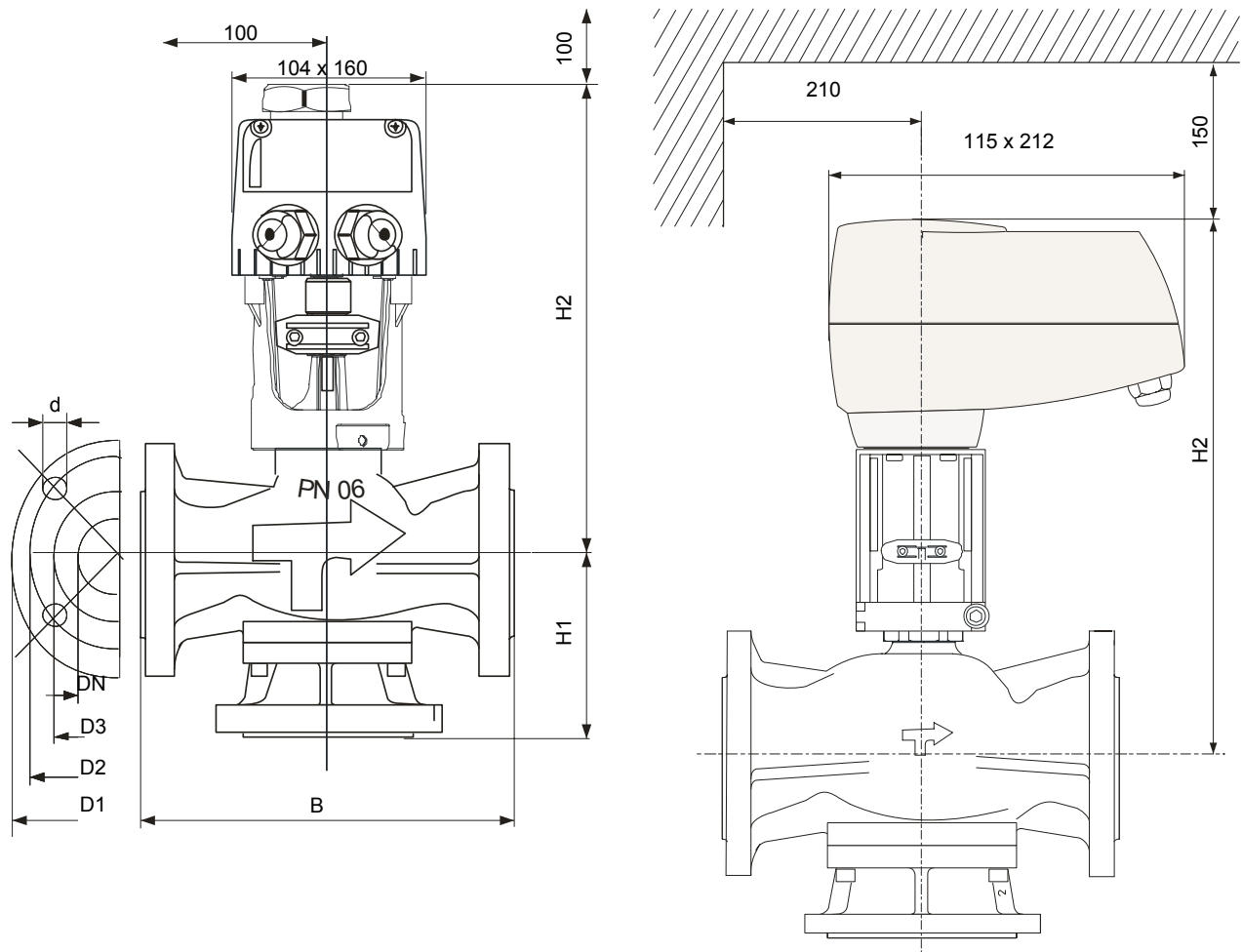

**Valve and actuator dimensions.**

DN	VA-7700		VA-7810	
	PN 6	PN 10	PN 6	PN 10
15	208		272	
20	208		272	
25	232		296	
32	243		307	
40	242		306	
50	249		313	
65	-		341	
80	-		-	
100	-		-	

DN	PN 6								PN 10							
	B	D1	D2	D3	d	H1	Holes	B	D1	D2	D3	d	H1	Holes		
15	130	80	55	38	11	65	4	130	95	65	46	14	65	4		
20	140	90	65	48	11	70	4	150	105	75	56	14	75	4		
25	150	100	75	58	11	75	4	160	115	85	65	14	80	4		
32	180	120	90	69	14	90	4	180	140	100	76	19	90	4		
40	180	130	100	78	14	90	4	200	150	110	84	19	100	4		
50	200	140	110	88	14	100	4	230	165	125	99	19	115	4		
65	240	160	130	108	14	120	4	290	185	145	118	19	145	4		
80	260	190	150	124	19	130	4	310	200	160	132	19	155	8		
100	300	210	170	144	19	150	4	350	220	180	156	19	175	8		

# Specifications

<b>Product</b>		VG9000 Series flanged valves									
<b>Models</b>		2-way PDT0; 3-way mixing									
<b>Service</b>		Water, glycol solutions (max. 50%) for HVAC applications (proper water treatment is recommended, refer to VDI 2035)									
<b>Valve body data:</b>	<b>DN</b>	15	20	25	32	40	50	65	80	100	
	<b>K<sub>vs</sub></b>	(*)	6.3	10	16	25	40	63	100	160	
<b>Weight (kg) PN 6/PN 10</b>	<b>2-way</b>	2.1/2.8	2.6/3.4	3.3/4.2	5.4/6.7	6.1/8.2	6.9/10.4	11.4/15.9	17.8/22.5	24.2/31.1	
<b>PN 6/PN 10:</b>	<b>3-way</b>	2.5/3.5	3.3 / 4.5	4/5.4	6.6/8.9	7.4/10.4	8.8/13.6	13.6/20.6	21.1/28.1	27.8/37.8	
<b>Nominal stroke</b>		8 mm		13 mm		19 mm			25 mm		
<b>Body pressure rating (EN 1092-2)</b>		<b>PN 6</b> 600 kPa Up to 120°C; 560 kPa at 140°C					<b>PN 10</b> 1000 kPa Up to 120°C; 930 kPa at 140°C				

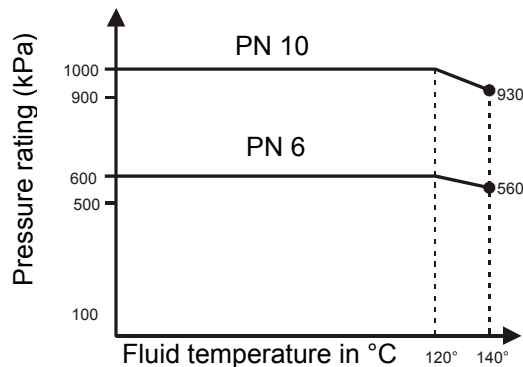

<b>Face to face dimensions</b>	DIN EN EN 558-1; Flanges DIN EN 1092-2	
<b>Fluid temperature limits</b>	+2...+140 °C	
<b>Body surface protection</b>	Blue lacquer	
<b>Material</b>		
<b>Body</b>	EN 1561 GJL250 (GG25)	
<b>Stem</b>	Stainless steel, (X5CrNiMo1712)	
<b>Plug</b>	Brass (CuZn40Pb2), with soft seat – FKM rubber Viton B	
<b>Seat</b>	Cast iron in 2-way and 3-way valves (integral to the body)	
<b>Dual u-cup ring packing</b>	Self adjusting Ethylene, Propylene, Rubber (EPR) U-cup ring pack	
<b>Flow characteristics</b>	Two-way valves and 3-way control port	3-way valves bypass port
<b>Control characteristics</b>	Equal percentage	Linear
<b>Practical rangeability</b>	$k_{vs} / k_{vr} > 25:1$	
<b>Sensitivity (ideal rangeability)</b>	$n_{gl} = 3.22$	-
<b>Leakage</b>	Max. 0.01% of $k_{vs}$ DIN EN 1349 IV L1	
<b>Operating pressure drop</b>	DN 15...DN 25 max. 150 kPa	DN 32... DN 100 max. 100 kPa,
<b>Shipping/storage</b>	-20°C	
<b>Standards and specifications</b>	DIN EN60534-1, DIN EN1092-2, DIN EN 1349, PN 10 is also as per DIN EN558-1	

(\*)  $K_{vs}$  coefficients for DN 15 valves (see also "Ordering codes for valve bodies")

0.63	1.0	1.6	2.5	4
------	-----	-----	-----	---

The performance specifications are nominal and conform to acceptable industrial standards. For application at conditions beyond these specifications, consult your local Johnson Controls office. Johnson Controls Incorporated is not liable for damages resulting from misapplication or misuse of its products.

**JOHNSON  
CONTROLS**

**Johnson Controls International, Inc.**

Headquarters:

European Customer Service Centre:

European Factories:

Branch Offices

Milwaukee, Wisconsin, USA

Westendhof 3, D-45143 Essen, Germany

Essen (Germany), Leeuwarden (The Netherlands) and Lomagna (Italy)

Principal European Cities.

: Printed in Germany