

T600 Series Programmable Thermostat

The T600 Series of programmable thermostats are specifically designed for control of commercial heating and cooling equipment such as rooftop units (with and without economizers), heat pumps, and single and multi-stage equipment. The seven-day, two or four event, thermostats are easy to set up and program through the use of a plain text menu driven backlit display that walks the user through the programming process. Additionally, the T600 has over twenty configurable parameters, enabling the thermostats to adapt to a variety of applications.

The T600 Series of programmable thermostats includes four models: Single-stage (T600HCP-1), Multi-stage (T600MSP-1), Heat Pump (T600HPP-1), and Economizer (T600MEP-1). All thermostats use a unique proportional control algorithm that virtually eliminates temperature offset associated with traditional differential based thermostats.



Figure 1: T600 Series Thermostat

Features and Benefits	
<input type="checkbox"/> Liquid Crystal Display (LCD)	Provides real-time control status of the environment in easy-to-read plain text messages
<input type="checkbox"/> Backlit Display	Incorporates a low level backlight during normal operation which brightens during user interaction
<input type="checkbox"/> Five Easy-to-Use Interface Keys	Allow for easy programming and configuration of the thermostat's many options (eliminates the need for dipswitches)
<input type="checkbox"/> Three Light-Emitting Diodes (LEDs)	Provides fan, heating, and cooling status at a glance
<input type="checkbox"/> Two Digital Inputs	Provides additional inputs for service or filter alarms, remote Night Setback (NSB), or remote override
<input type="checkbox"/> Configurable Auxiliary Output	Equipped with a configurable output that operates in coordination with the programmed schedule
<input type="checkbox"/> Over Twenty Configurable Parameters	Enables the thermostat to adapt to any installation
<input type="checkbox"/> Economizer Output (T600MEP-1)	Controls economizer operation for single and multi-stage unitary rooftop equipment

Product Overview

The T600 Series of programmable thermostats are specifically designed for control of the most common commercial heating and cooling equipment. The fully programmable seven day, two or four event schedule, along with a number of configurable parameters, including two programmable digital inputs and one configurable output, enable effective and efficient control of equipment in nearly any application. All programming, configuration, setup, and operation of the T600 are extremely intuitive and are accomplished through the user interface.

IMPORTANT: Use the T600 programmable thermostat only as an operating control. Where failure or malfunction of these thermostats could lead to personal injury or property damage to the controlled equipment or other property, additional precautions must be designed into the system. Incorporate and maintain other devices such as supervisory or alarm systems or safety or limit controls intended to warn of, or protect against, failure or malfunction of the T600 programmable thermostats.

Additional Features

The T600 Series of non-programmable thermostats also offers many other features:

- **Menu Driven Options**
Eliminates the need for dipswitches, setup of all configurable parameters is menu driven.
- **Three LEDs**
Provides fan, heating, and cooling status at a glance.
- **Adjustable Heating/Cooling Deadband**
Adjusts the minimum heating/cooling deadband from 2 to 4F° (1 to 2C°).
- **Two Configurable Digital Inputs**
Provides additional inputs for service or filter alarms, remote NSB, or remote override.
- **Adjustable Maximum Heating/Minimum Cooling Setpoints**
Establishes the maximum heating setpoint and minimum cooling setpoint that can be entered through the user interface.
- **One Configurable Auxiliary Output**
Includes a Single-Pole, Single-Throw (SPST) auxiliary output that operates with the thermostat's schedule. The output can be configured as normally open or normally closed.
- **Seven-Day, Two or Four-Event Schedule**
Allows configuration for a two or four event schedule. Additionally, each day of the week can be individually programmed to suit the required schedule.
- **Progressive Recovery**
Assures the correct temperature is reached at the programmed occupied time.
- **Adjustable Heating/Cooling Cycles per Hour**
Configurable for the number of heating and cooling cycles in a one-hour period, balancing temperature control and equipment cycling.
- **Smart Fan**
Enables the fan to operate continuously during the occupied times and cycle with the equipment during the unoccupied times.
- **Remote Indoor and Outdoor Sensing**
Accommodates remote indoor and outdoor sensors. Up to three indoor sensors can be averaged.
- **Adjustable Anti-Short Cycling Timer**
Adjusts the minimum on and off times for the equipment from 0 to 5 minutes.
- **Three Levels of Keypad Lockout**
Provides three different levels of keypad lockout that can be set up through the menu and interface keys.
- **Concealed Key to Access Configuration Parameters**
Enables access to all configurable parameters while limiting unwanted parameter tampering once the thermostat is set up.
- **Adjustable Power Delay on Start-up**
Enables a delay before any operation is authorized upon power-up of the thermostat. Can be used for equipment protection or to sequence start-up of multiple units in one location.
- **Frost Protection**
Turns the heat on when the zone temperature drops below 42°F (5.5°C) regardless of the thermostat's mode.
- **Adjustable Temporary Occupancy Time**
Adjusts the occupancy override time from 0 to 12 hours.
- **High and Low Balance Point Adjustments (T600HPP-1)**
Enables more precise control of heat pump operation based on outdoor air temperature.

- **System Mode Lockout**
Allows the heating and cooling modes to be locked out based on outdoor air temperature when an outdoor air sensor is connected.
- **Non-Volatile EEPROM Memory**
Prevents loss of adjusted parameters during power failure.
- **Power Loss Backup for Clock**
Retains clock setting for up to 6 hours in case of power loss.
- **Heating and Cooling Stage Enable/Disable (T600MSP and T600MEP-1) or Heat Pump Compressor Stage Enable/Disable (T600HPP-1)**
Allows operation of the second-stage heating and cooling to be disabled, reverting the thermostat to single-stage operation, on heat pump and multi-stage thermostats.
- **Fan Operation Control**
Enables the user to select how the fan operates on a call for heating and the delay at the end of the heating or cooling cycle.

Thermostat Interface Keys

The T600 interface consists of five keys on the front cover and one configuration key (see Figure 2) that can be accessed by removing the front cover. The functions of the keys are as follows. Use the:

- YES key to confirm a selection and move onto the next menu item
- NO key when you do not desire a parameter change, and to advance to the next menu item
- MENU key to access the Main User Menu or exit the menu
- DOWN arrow key to scroll through menu selections or adjust values
- UP arrow/SCROLL key to:
 - scroll through menu selections or adjust values
 - stop the Status Display Menu from scrolling and to manually scroll to the next parameter on the menu. When left unattended for 45 seconds, the display resumes scrolling.

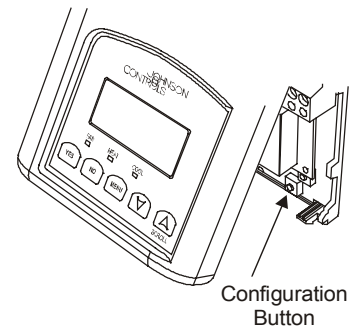

Figure 2: Configuration Key Location

LCD Backlit Display

The T600 uses a two-line, eight-character backlit display. Low level backlighting is present during normal operation and it brightens when any user interface key is pressed. The backlight returns to the lower level when the thermostat is left unattended for 45 seconds.

Light-Emitting Diodes (LEDs)

Three LEDs are used to indicate the status of the fan, call for heat, or call for cooling on the T600HCP-1, T600MSP-1 and T600MEP-1. When:

- the fan is on, the FAN LED lights up
- heating is on, the HEAT LED lights up
- cooling is on, the COOL LED lights up

On the T600HPP-1, the three LEDs indicate heat pump operation. When:

- the fan is on, the FAN LED lights up
- the auxiliary heat is on, the AUX HEAT LED lights up
- the heat-pump compressor is on, the HEAT-PUMP LED lights up

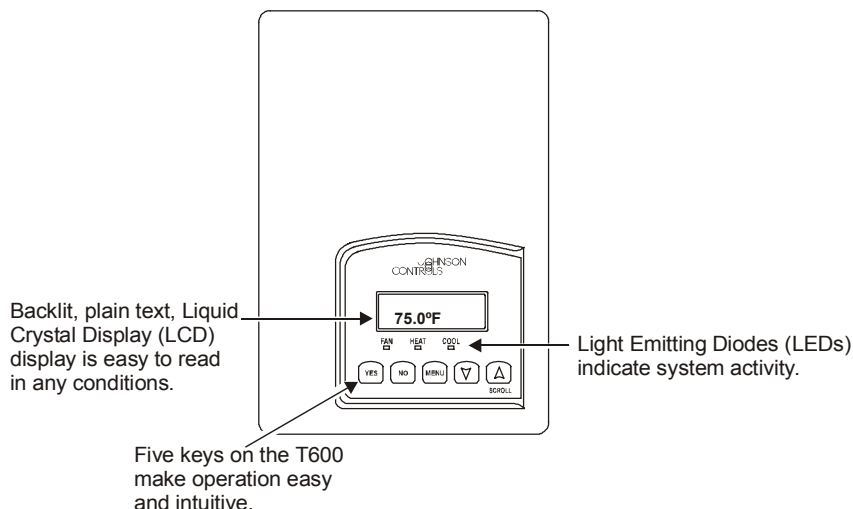

Figure 3: T600 Front Cover

Menu Overview

There are three menus used to view, program, and configure the T600 Series thermostats. The menus are:

- Status Display Menu
- Main User Menu
- Installer Configuration Menu

The following sections outline the functions and contents of each menu.

Status Display Menu

The Status Display Menu is displayed during normal thermostat operation. The menu continually scrolls through the following parameters:

- Room Temperature
- Clock
- System Mode
- Schedule Status (Occupied/Unoccupied)
- Outdoor Temperature (requires outdoor air temperature sensor)
- Applicable Alarms

Pressing the up arrow/SCROLL key temporarily stops the scrolling.

Main User Menu

The Main User Menu is used to access and change the thermostat's basic operating parameters. The Main User Menu is accessed by pressing the MENU key during normal thermostat operation. This menu is most commonly used by the zone occupant and is comprised of the following parameters:

- Schedule Override/Resume
- Temperature Setpoints
- System Mode
- Fan Mode
- Schedule Set
- Clock Set
- Permanent Hold Schedule

The Main User Menu uses Auto Help. Auto Help is displayed automatically in the Main User Menu when there is a pause in programming activity.

Installer Configuration Menu

The Installer Configuration Menu is used to setup the thermostat for application specific operation. Access the menu by removing the front cover and pressing the configuration key, labeled CONFIG (see Figure 2).

The Installer Configuration Menu is used by the installer/commissioning technician and contains the following parameters.

- Digital Input Configuration
- Keypad Lockout Levels
- Power Delay on Power-up
- Frost Protection
- Maximum Heating Setpoint/Minimum Cooling Setpoint
- Anti-Short Cycle Timer
- Heating Stages Cycles per Hour
- Cooling Stages Cycles per Hour
- Minimum Deadband
- Heating Fan Control
- End of Cycle Fan Delay
- Temporary Occupancy Time
- Room Sensor Calibration
- Outdoor Air Sensor Calibration
- Number of Heating Stages (T600MSP-1 and T600MEP-1)
- Number of Cooling Stages (T600MSP-1 and T600MEP-1) or Number of Heat Pump Stages (T600HPP-1)
- Heating Operation Lockout Based on Outdoor Air Temperature
- Cooling Operating Lockout Based on Outdoor Air Temperature
- Two or Four Events per Day Configuration
- Auxiliary Output Configuration
- Enable/Disable Progressive Recovery

The following parameters are for the T600HPP-1 only:

- Low Balance Point
- High Balance Point
- Comfort/Economy Heat Pump Operation
- Reversing Valve Operation
- Compressor/Auxiliary Interlock

The following parameters are for the T600MEP-1 only:

- Economizer Changeover Setpoint
- Outdoor Air Minimum Position
- Mechanical Cooling Operation w/ Economizer
- Mixed Air Temperature Setpoint
- Displaying the Mixed Air Temperature

Dimensions

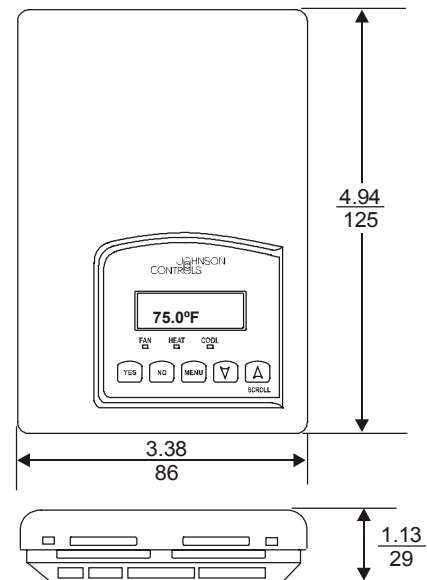

Figure 4: T600 Dimensions (in./mm)

Ordering Information

Code Number	Description	Applications
T600HCP-1	Single-Stage Programmable Thermostat	Fan Coil Units, Unit Heaters, and Single-Stage Packaged Heating/Cooling Equipment
T600MSP-1	Multi-Stage Programmable Thermostat	Multi-Stage Packaged Heating/Cooling Equipment
T600HPP-1	Heat Pump Programmable Thermostat	Heat Pump with up to 3 Heating/2 Cooling Stages
T600MEP-1	Economizer Programmable Thermostat	Packaged Rooftop Units with Economizers

Accessories

Code Number	Description
SEN-600-1	Remote Indoor Temperature Sensor
SEN-600-2	Outdoor Air Temperature Sensor
SEN-600-3	Duct Mount Temperature Sensor
SEN-600-4	Remote Indoor Temperature Sensor with Occupancy Override Button and LED

Technical Specifications

Product	T600HCP-1	Programmable Thermostat, Single-Stage
	T600MSP-1	Programmable Thermostat, Multi-Stage
	T600HPP-1	Programmable Thermostat, Heat Pump
	T600MEP-1	Programmable Thermostat, Multi-Stage with Economizer Control
Power Requirements	20-30 VAC, 50/60 Hz, 24 VAC nominal, Class 2	
Relay Contact Rating Maximum Inductive	1 ampere with in-rush surges up to 3 amperes, 30 VAC maximum, Class 2	
Digital Inputs	Relay dry contact only across the C terminal to DI1 and DI2	
Economizer Output	0 to 10 VDC into 2 K ohm resistance minimum (T600MEP-1 only)	
Recommended Wire Size	18 gauge maximum, 22 gauge recommended	
Thermostat Measurement Range	-40 to 122°F (-40 to 50°C)	
Sensor Type:	Local 10 K ohm NTC thermistor	
Resolution:	±0.2F° (±0.1C°)	
Control Accuracy	±0.9F° (±0.5C°) @ 70°F (21°C) typical calibrated	
Outdoor Air Temperature Indication Range	-40 to 122°F (-40 to 50°C)	
Control Range	Cooling: 54 to 100°F (12 to 37.5°C) in 1/2 degree increments Heating: 40 to 90°F (4.5 to 32°C) in 1/2 degree increments	
Minimum Deadband	(Between heating and cooling) 2F° or 1C°	
Ambient Operating Conditions	32 to 122°F (0 to 50°C); 0 to 95% RH noncondensing	
Ambient Storage Conditions	-22 to 122°F (-30 to 50°C); 0% to 95% RH noncondensing	
Dimensions (H x W x D)	4.94 x 3.38 x 1.13 in. (125 x 86 x 29 mm)	
Shipping Weight	0.75 lb (0.34 kg)	
UL and cUL Listing	File E27734 with CCN's XAPX (US, UL 873) and XAPX7 (Canada, CSA C22.2 No. 24)	
CE Compliance	CE Directives EN50091-1: 1992 EMC Emissions; EN50082-2 EMC Immunity	
FCC Compliance	This equipment has been tested and found to comply with the limits for a Class A digital device and verified to Class B pursuant to Part 15 of FCC Rules. These limits are designed to provide reasonable protection against harmful interference when this equipment is operated in a commercial environment. This equipment generates, uses, and can radiate radio frequency energy and, if not installed and used in accordance with the instruction manual, may cause harmful interference to radio communications. Operation of this equipment in a residential area is likely to cause harmful interference in which case the user will be required to correct the interference at his/her own expense.	

The performance specifications are nominal and conform to acceptable industry standards. For application at conditions beyond these specifications, consult the local Johnson Controls office. Johnson Controls, Inc. shall not be liable for damages resulting from misapplication or misuse of its products.

This device complies with Class A Part 15 of the FCC rules. It was also verified to Class B. Operation is subject to the following two conditions:

- (1) This device may not cause harmful interference.
 - (2) This device must accept any interference received, including interference that may cause undesired operation.
- This Class A digital apparatus meets all of the requirements of the Canadian Interference-Causing Equipment Regulations. Cet appareil numérique de la Classe A respecte toutes les exigences du Règlement sur le matériel brouilleur du Canada.



Controls Group
507 E. Michigan Street
P.O. Box 423
Milwaukee, WI 53201

Published in U.S.A.
www.johnsoncontrols.com